

Simple and rapid solution for all your mixing needs



Efficient

- Optimal tempering of wheat prior to milling
- Efficiently mix flours and other powders (additives, etc.)

Simple and robust

- Mixers have a built-in timer

MR10L

10 liter plastic bottle

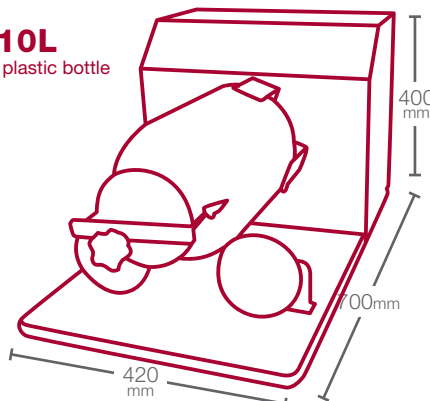

23 Kg ⚡ 220V - 50Hz ⚙ 60 t./min

MR2L

2 liter plastic bottle

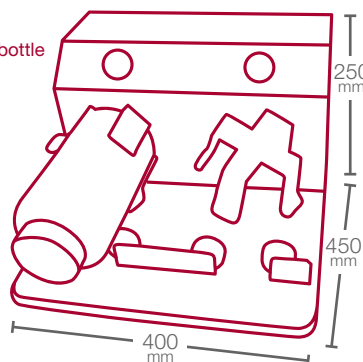

10 Kg ⚡ 220V - 50Hz ⚙ 60 t./min



Test time : **30 minutes**
Operator time : **20 seconds**

Principle

The particles of the product to be homogenized or mixed are subjected to a lateral transfer movement and swept along by the rotary movement applied to the bottle.

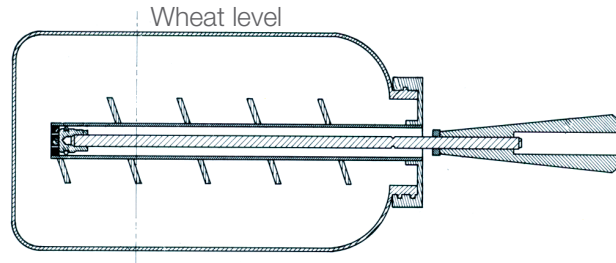

- a right-hand screw is used for homogenization or mixing of particles between 0.5 mm and 5 mm., as well as the addition of liquids.
- a bidirectional worm screw is used for homogenization or mixing of particles between 50 and 500 μ .

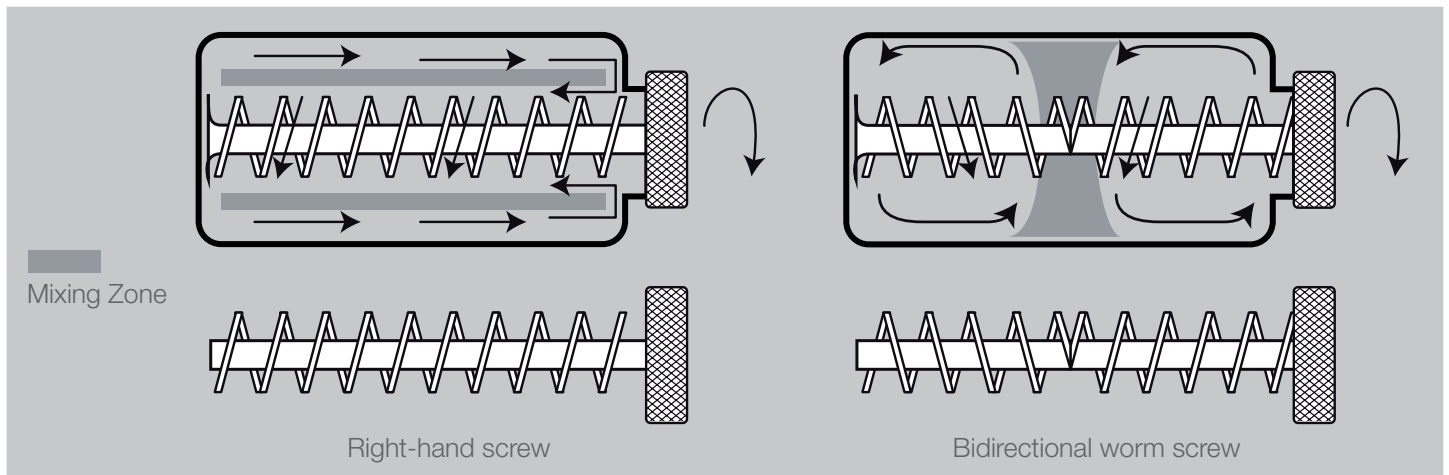

Water or non-corrosive liquids may be added using the right-hand screw, the shaft of which is hollow and pierced in its lower side. This allows the distribution of the liquid in the sample before it moves up in the apparatus.

Benefits

MR2L and MR10L mixers are used to condition wheat before test milling. They are also used for a wide range of other mixing applications :

- powders
- grains or granular products
- powders with granular products
- liquids with granular products

Mixers are supplied with 2 mixing screws: one suitable for grain mixtures, the other for mixes of other powders.